

New Product Release

Poseidon 6.5" Hand Held Rugged Monitor



- 6.5" Hand Held Colour TFT rugged LCD monitor
- Ultra slim & lightweight
- VGA or XGA resolution Options
- RGB interface
- Optional composite video interface
- High brightness and Sunlight Viewability
- Wide Voltage Input 9-36 V DC-DC converter option
- Touchscreen option, Serial or USB interface
- Sunlight readable display option
- Deep Dimming option
- Fully hermetically sealed to IP65 as standard
- Sealing to IP 67/68 on application
- Single umbilical cable
- Integral RISC Computer option



Bluestone Technology Ltd

Product Information

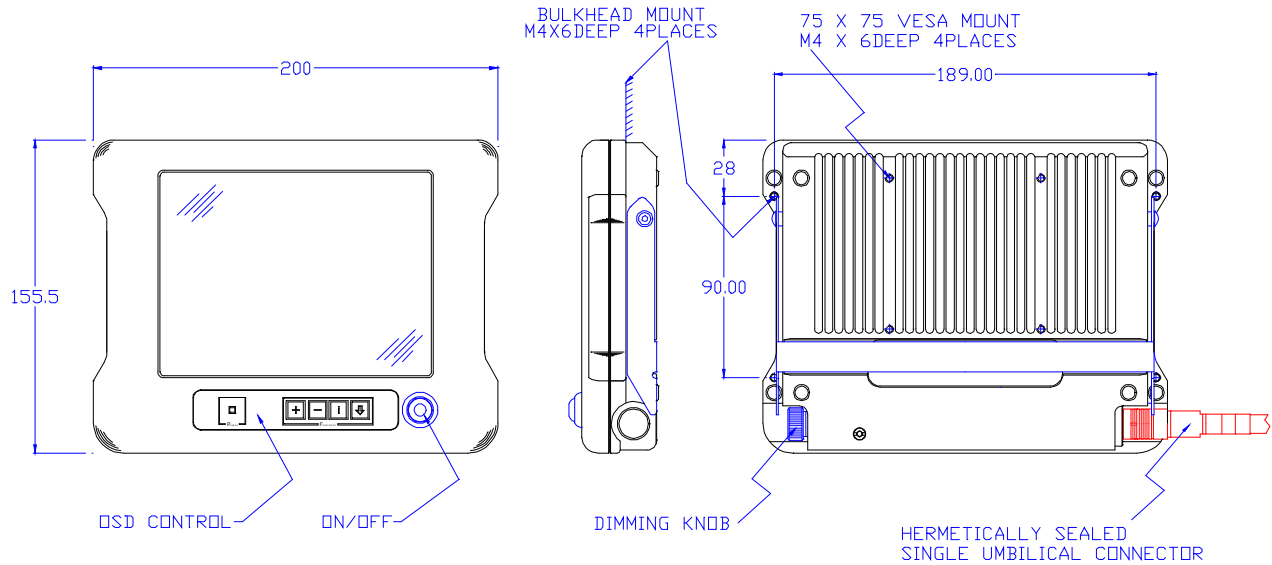

Description

The Poseidon 6.5" monitor is a continuation of our well proven Poseidon hand held monitor range which is already in service in a vast range of applications. Ideally suited to a wide range of mobile hand held or vehicle mounted applications where extreme slimness and light weight, compact size, rugged reliability, high brightness, sunlight viewability and full hermetic sealing to IP 65 or greater is necessary. The bright high contrast display allows excellent readability under a wide range of ambient lighting conditions while keeping power consumption to an absolute minimum, making it ideal for many mobile display applications such as military and marine chart plotting / mapping, instrumentation test equipment and surveillance displays. A sunlight readable passively enhanced display option is available which is highly suited to outdoor and marine applications. Various other options are available to complement the monitors such as touch screens, custom mountings and stands and deep dimming to name a few. Another important feature of this monitor is the extended support life of the display ensuring continuity of through life support which is critical for many military applications. Please contact us for more details of the many options available and to discuss your specific requirements in detail.

Technical Data

Display Size	6.5" Diagonal	Sealing	IP65 Fully Hermetic sealing
Resolution	VGA or XGA	Optional	IP67/68
Brightness	500 Cd/m sq	Weight	1Kg
Contrast Ratio	600:1	Temp Operating	-20 to + 70 Deg C
Colours	16.2 Million	Temp Storage	-20 to + 80 Deg C
Interface	RGB	Touch Screen	Serial or USB Interface
Optional	Comp Video	Connection	Via Single umbilical Cable
100% Dimming	Via Rotary Pot Control	Power	12 V DC 12W
On Off switch	Optional power switch		Optional 9-36 V DC input
Rear VESA mount	75 x 75m VESA mounting		

Bluestone Technology reserves the right to implement changes in design and technology which serve to improve the product. Specifications are subject to minimal alterations for production reasons.

1 Paiges Farm, Bovisand Lane, Down
Thomas, Plymouth PL9 0AE
Tel / Fax +44 (0)1752 862436
E Mail sales @bluestonetechnology.com
Web Site www.bluestonetechnology.co.uk

Bluestone
Technology Ltd